



Multi-Stack® Frame

Pre-Assembled Welded Construction – No Field Assembly Required

Another Space-Saving Idea

Lochinvar's Copper-Fin technology not only makes our water heaters and boiler more efficient, it means they also have a smaller footprint. So they save space, as well as operating costs.

And now there's a way to get greater flexibility and reliability, save even more space, and get a system that's perfectly matched to a facility—thanks to the Multi-Stack Frame from Lochinvar.

Match Load And Capacity

With this versatile stand, you can stack almost any combination of our Copper-Fin®, Copper-Fin II®, Efficiency+®, and Solution™ water heaters and boilers. So you can achieve the perfect Btu/hr capacity for each application.

For example, a facility needs a Copper-Fin II boiler with a total capacity of 1.6 million Btu/hr. Instead of installing an oversized CHN1801 unit or a smaller CHN1441 model, now you can combine two units – CHN991 and CHN651 models – to exactly match the facility's needs.

Plus, the total footprint of this combined system is just over 10 inches wider than the CHN651 unit alone, making it smaller than either the CHN1801 or CHN1441 model. All thanks to the Lochinvar Multi-Stack Frame.



Two Lochinvar 990,000 Btu/hr Copper-Fin II water heaters stacked for a total capacity of almost 2 million Btu/hr.

No Assembly Required

Lochinvar's Multi-Stack Frame is fully factory assembled and shipped in one piece. The frame is welded using square steel tubing by certified welders. Each frame is designed and tested for specific application.

Added System Benefits

This modular design provides two other important benefits. First, it allows for system turndown for greater efficiency when demand is lower. And second, it ensures against system failure by utilizing two independent but complimentary units. For residential and light commercial needs or commercial applications of up to 4 million Btu/hr the Multi-Stack Frame gives greater flexibility without a significant increase in stack size or overall system dimensions.

Once you've determined a facility's requirements and the exact models needed, utilize the charts provided to calculate total system dimensions.



Our compact Efficiency+ requires even less space when stacked on a Multi-Stack Frame.



Look for this logo in our water heater and boiler catalogs for products that use this space saving idea.

NOTE: Multi-Stack Frames are for indoor applications only.

Dimensions and Specifications

Solution™ Boilers/Copper-Fin® Water Heaters & Boilers (Models 045-500)

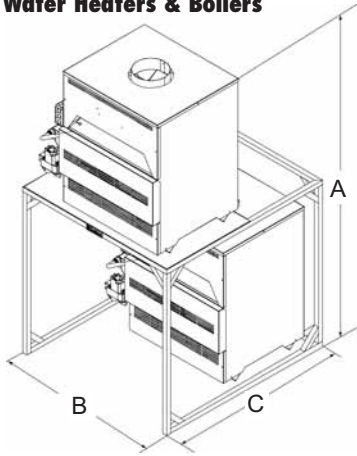

MODEL #	PART #	A*	B**	C	Wt. (.lbs)
CB 045	MSF 3034	65-1/2"	36"	39"	73
CB 075	MSF 3034	65-1/2"	36"	39"	73
CB/CW 090	MSF 3034	65-1/2"	36"	39"	73
CB/CW 135	MSF 3034	65-1/2"	36"	39"	73
CB/CW 180	MSF 3034	65-1/2"	36"	39"	73
CW 199	MSF 3035	65-1/2"	48"	39"	84
CB 215	MSF 3035	65-1/2"	48"	39"	84
CW 225	MSF 3035	65-1/2"	48"	39"	84
CB 260	MSF 3035	65-1/2"	48"	39"	84
CW 270	MSF 3035	65-1/2"	48"	39"	84
CB/CW 315	MSF 3035	65-1/2"	48"	39"	84
CB/CW 360	MSF 3035	65-1/2"	48"	39"	84
CB/CW 399	MSF 3036	65-1/2"	65"	39"	147
CB/CW 500	MSF 3036	70-1/2"	65"	39"	147

Efficiency+® Water Heaters and Boilers (Models 150-300)

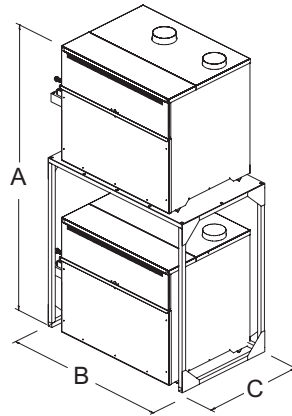

MODEL #	PART #	A*	B**	C	Wt. (.lbs)
EB/EW 150	MSF3021	71-1/4"	37"	24"	72
EB/EW 200	MSF3021	71-1/4"	37"	24"	72
EB/EW 250	MSF3021	71-1/4"	37"	24"	72
EB/EW 300	MSF3021	71-1/4"	37"	24"	72

Note: Heater height is 28" on all models.

Copper-Fin® Water Heaters and Boilers (Models 495-745) (Models 986-2066)

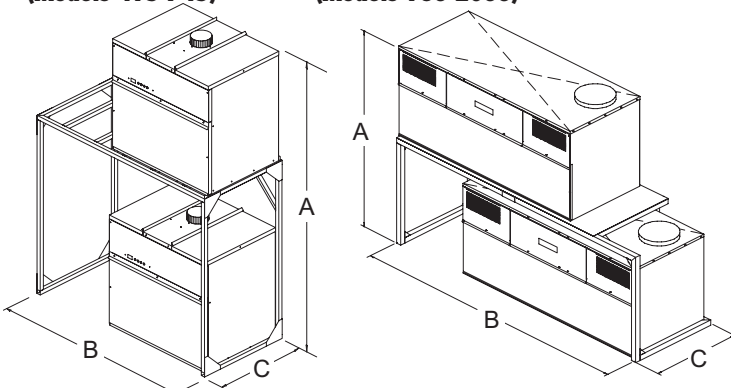

MODEL #	PART #	A*	B**	C	Wt. (.lbs)
CB/CW 495	MSF3002	81-1/2"	51"	24-1/2"	70
CB/CW 645	MSF3003	84-1/2"	70"	26"	128
CB/CW 745	MSF3003	84-1/2"	70"	26"	128
CB/CW 986	MSF3007	80"	68"	36"	170
CB/CW1256	MSF3008	80"	88"	36"	214
CB/CW1436	MSF3008	80"	88"	36"	214
CB/CW1796	MSF3009	80"	114"	36"	251
CB/CW 2066	MSF3009	80"	114"	36"	251

Note: Heater Height is 33-1/4" (495-745) & 36" (986-2066)

Copper-Fin II® Water Heaters, Boilers and Pool Heaters (Models 401-751) (Models 991-2071)

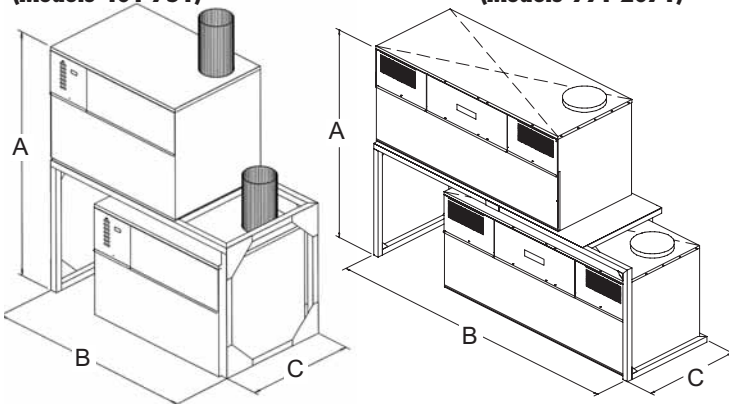

MODEL #	PART #	A*	B**	C	Wt. (.lbs)
CH/CF 0401	MSF3022	67-1/2"	59"	24-1/2"	83
CH/CF/CP 0501	MSF3022	67-1/2"	59"	24-1/2"	83
CH/CF/CP 0651	MSF3023	67-1/2"	80"	24-1/2"	132
CH/CF/CP 0751	MSF3023	67-1/2"	80"	24-1/2"	132
CH/CF/CP 0991	MSF3007	80"	68"	36"	170
CH/CF/CP 1261	MSF3008	80"	88"	36"	214
CH/CF/CP 1441	MSF3008	80"	88"	36"	214
CH/CF/CP 1801	MSF3009	80"	114"	36"	251
CH/CF/CP 2071	MSF3009	80"	114"	36"	251

Note: Heater height is 31-1/2" (401-751) & 36" (991-2071)

* To vent connection

** Allow space for plumbing connections



Lochinvar®
High Efficiency Water Heaters, Boilers and Pool Heaters

Lochinvar Corporation • 300 Maddox Simpson Pkwy • Lebanon, TN 37090 • 615-889-8900 / Fax: 615-547-1000

www.Lochinvar.com