



LTV Low Temperature Valves

Non-Condensing Boiler Protection for Low Temperature Systems

Ideal for use with Copper-Fin, Copper-Fin II and Power-Fin Boilers

When designing a boiler system with return water temperatures below 130°F it is necessary to protect the boiler from condensation. All non-condensing boilers will develop operational problems if they are continually exposed to system return water temperatures below 130°F. Typical systems that require this protection are water source heat pump systems, in-floor radiant systems, greenhouse heating, soil heating, process operations and manufacturing operations. Other hydronic heating systems that may require low temperature protection are night setback, night/weekend shutdown and outdoor reset.

To prevent low return water temperatures, combat operational problems and prevent premature failure of the boiler, the system should be piped in a primary secondary piping arrangement with bypass. The problem with “manual” bypass systems is that flow in the system changes as load changes; however the “manual” bypass is not adjusted and operational problems still exist. A better alternative is Lochinvar’s Low Temperature Valve, which is a self-contained automatic thermostatic 3-way valve that ensures temperatures entering the boiler remain above 130°F.



Lochinvar offers the LTV Low Temperature Valve as a stand alone valve which requires the installer to supply the pump and all necessary piping. (2” LTV Valve shown installed on CHN751)

Standard Features

- Low Return Water Temperature Boiler Protection
- Non-Adjustable and Automatic
- Heavy Duty Construction
- Replaceable Element

How it Works

The LTV Valve “modulates” to maintain 140°F as a minimum return temperature to the boiler.

- Hot water from the boiler enters “B” port.
- Cooler water from the system enters “C” port.
- “B” and “C” water mix to meet the desired 140°F.
- Water exits “A” port back to the boiler return.

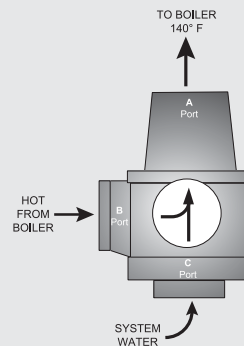

2” LTV Valve

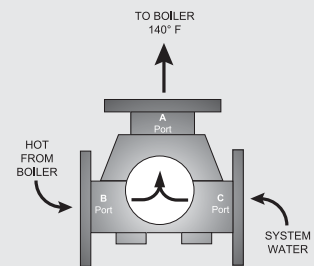

2-1/2” LTV Valve

LTV Valve Dimensions & Specifications

2" LTV Valve

Up to 750,000 Btu/hr
Part Number - VAL3048

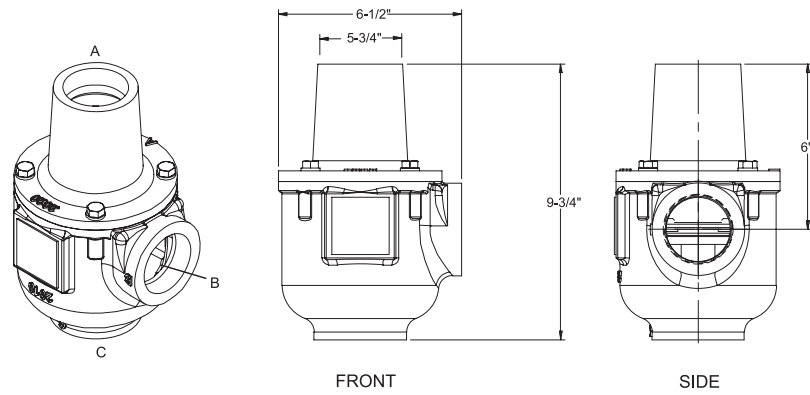

2-1/2" LTV Valve

990,000 Btu/hr and up
Part Number - VAL3047

Note: Mounting flange included with valves.

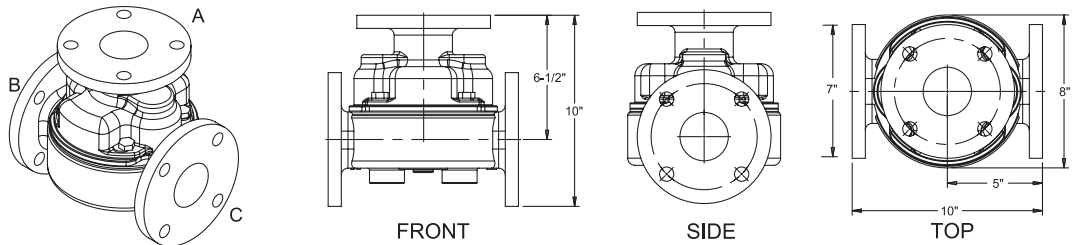

All boilers must use optional remote sensor. The LTV Valve is not recommended for high limits 205°F or less.

TYPICAL PIPING

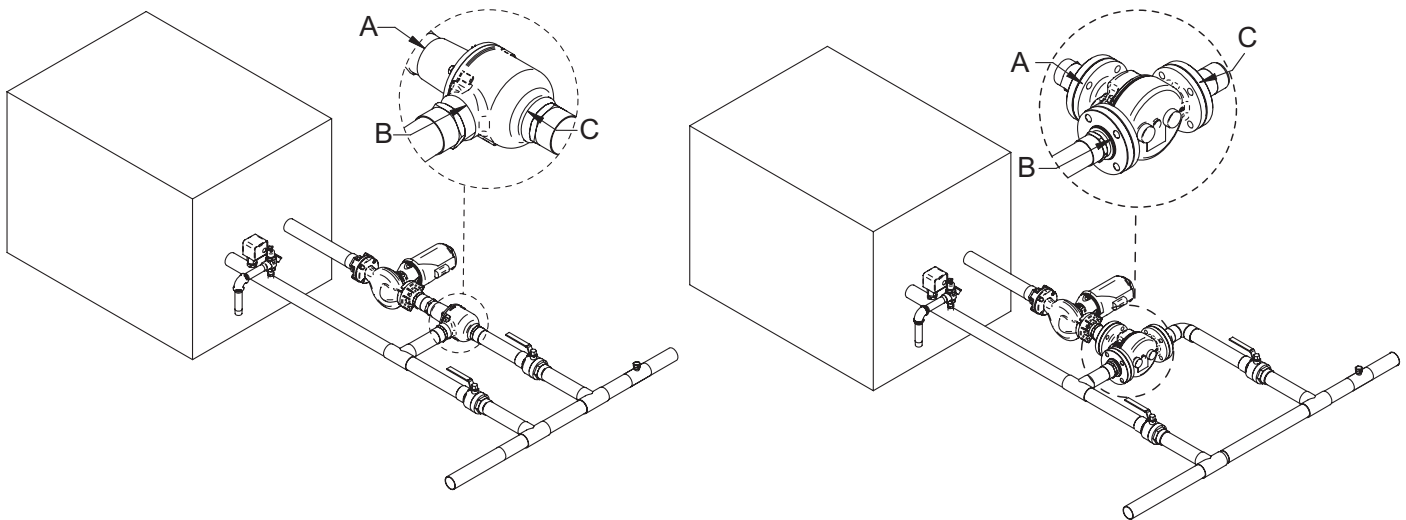

2" LTV Valve

2-1/2" LTV Valve



Lochinvar Corporation • 300 Maddox Simpson Pkwy • Lebanon, TN 37090 • 615-889-8900 / Fax: 615-547-1000

www.Lochinvar.com